

## Bella Vista MHP Owner's Statement

(Signature Required, provide with Residential Plot Plan Application)

1. **Dwelling Unit Construction:** All manufactured homes shall be partially or entirely manufactured in a factory; have brick, wood, vinyl or cosmetically equivalent exterior siding and a pitched roof; and are certified pursuant to the latest revisions of the "National Manufactured Housing Construction and Safety Standards Act of 1974," 42 U.S.C. 5401 et seq. as amended. All homes shall be installed in accordance with the installation guidelines for manufactured housing (ICBO), as adopted by the City of Evans.
  - A. Skirting. Each home shall have perimeter skirting between the ground and the bottom of the home floor within (30) thirty days after placement is made. Such skirting shall be durable, rigid weather-resistant material.
  - B. Perimeter enclosures must be designed and installed in accordance with the Uniform Building Code, as adopted by the City of Evans. Exterior treatments of perimeter enclosures must be stucco or similar type finishes.
  - C. All licensees, as well as owners and occupiers of homes, shall be required to comply with any requirements imposed by Colorado law or by regulations issued by any agency of the State of Colorado, including but not limited to the Colorado Division of Housing, pertaining to anchoring or tying down homes as a safety precaution against wind.
  - D. A deck/landing is required at all exterior doors complying with minimum standards as set forth by the International Building Code.
2. **Home Size, Minimum:** 16' wide by 68' long or 1,088 sq. ft. Only new homes and replacement homes **not be more than 4 years old of the manufactured date** shall be installed in the community.
3. **Home Placement / Spacing of Structures:** Each lot shall have a minimum 5' setback on all sides. Lots abutting adjacent private property shall have a minimum 10' setback from that property line. Details addressing spacing between structures shall be included with the site plan. Separation between structures shall be as follows:
  - A. Homes placed end-to-end shall have a minimum of a ten (10) foot separation.
  - B. Homes placed side-by-side shall have a minimum of twenty (20) foot separation.
  - C. Homes placed side-to-end shall have a minimum of fifteen (15) foot separation.
  - D. No home shall be located closer than ten (10) feet from any building within the park or from any property line bounding the park.
  - E. Homes including non-removable tow hitches shall be set back at least five (5) feet from private streets and roadways, and twenty-five (25) feet from public rights-of-way.
  - F. Carports shall maintain a five (5) foot separation from adjacent structures.
4. **Landscaping/Parks:** Landscaping layout shall conform to that illustrated in the attached Bella Vista PUD plan. All common landscaped areas (drainage areas, entry features, perimeter landscaping, sport court) will be owned and maintained by the owner of the Bella Vista community. Landscaping within individual home sites will be maintained by the individual homeowners consistent with leasing requirements set forth by the owners of the Bella Vista community. The owner of the Bella Vista community will install one (1) two-inch (2") caliper ornamental / small deciduous tree and five (5) five-gallon minimum container evergreen or deciduous shrubs on each lot to be located in such a manner that would not obstruct homes from moving on and off the lots.

## HOME SITE TYPICALS

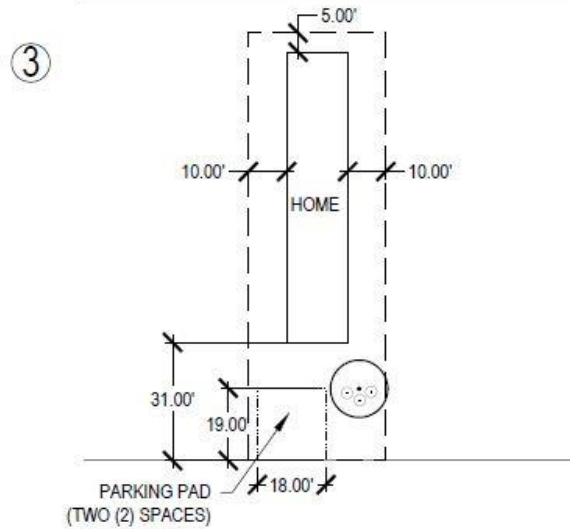
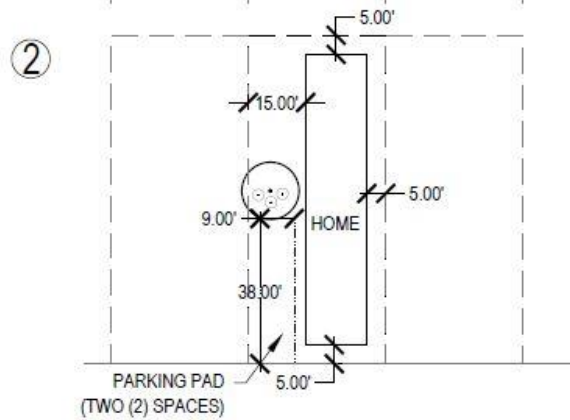
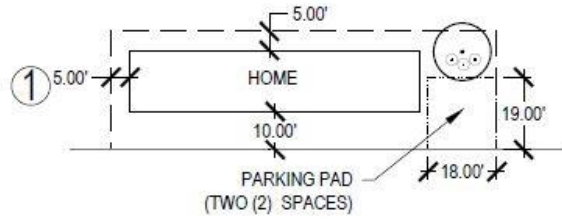

## SETBACK TABLE

SETBACK	STANDARD (MIN.)
HOMES PLACED END-TO-END	10'
HOMES PLACED SIDE-BY-SIDE	20'
HOMES PLACED SIDE-TO-END	15'
PROPERTY LINE	10'

### NOTES:

- HOME INCLUDING NONREMOVABLE TOW HITCHES SHALL BE SET BACK AT LEAST FIVE (5) FEET FROM PRIVATE STREETS AND ROADWAYS, AND TWENTY-FIVE (25) FEET FROM PUBLIC RIGHTS-OF-WAY.

5. **Maintenance:** The owner of a home shall be responsible for maintaining the exterior of the home, including but not limited to roofing, siding and skirting, in good condition and shall promptly replace or repair any damage or defects to such exterior. The owner of a home shall be responsible for maintaining the yard or open space within his or her designated home space, including but not limited to keeping such area free of weeds, trash or other violation of the municipal code. Any such violation shall be punishable in accordance with the requirements of the municipal code, as applicable.
  
6. **Occupancy:** Building permit issuance shall be in accordance with the standard operational procedures of the city. No occupancy certificates will be issued until the subject building site is completed and accepted by the city.
  
7. **Setbacks:** Setbacks for manufactured homes shall be a minimum of five (5) feet on the front and rear, five (5) feet on one side and fifteen (15) feet on the opposite side. Accessory storage shed shall be setback a minimum of five (5) feet.
  
8. **Storage Units:** One storage unit may be placed on each home site to address storage of residentially permitted uses. Storage units must be a minimum of ten (10) feet from the Bella Vista property line and five (5) feet from adjacent structure. Accessory structures shall only be permitted in accordance with the requirements of the Evans Municipal Code. No storage shall be permitted underneath any home unless properly designed and enclosed with skirting. No flammable, combustible or hazardous material shall be stored underneath any home.

**Applicant Information & Signature**

**Applicant Name (Printed):** \_\_\_\_\_

**Address:** \_\_\_\_\_

**Telephone:** \_\_\_\_\_

**E-Mail:** \_\_\_\_\_

The undersigned certifies they have read and understand the requirements above for the location and placement of a manufactured home in the Bella Vista Manufactured Home Park. The undersigned further states the placement of the unit at the address above satisfies the above standards for the Bella Vista Manufactured Home Park.

---

**Signature of Applicant** **Date**

---

**Signature of Applicant** **Date**

